



JOCSZ21X-M4,JOCSZ31X-M4 Series

Rev.A.1.0

DESCRIPTION:

The products are 4-pin thyristor opto-couplers. The device combines an AlGaAs infrared emitting diode as the emitter which is optically coupled to a monolithic silicon zero-crossing photo triac in a plastic SOP4 package. The products are widely used in solenoid/valve controls, lighting controls, motor controls, temperature controls, static AC power switches, solid state relays, interfacing microprocessors up to 265 V_{AC} peripherals.

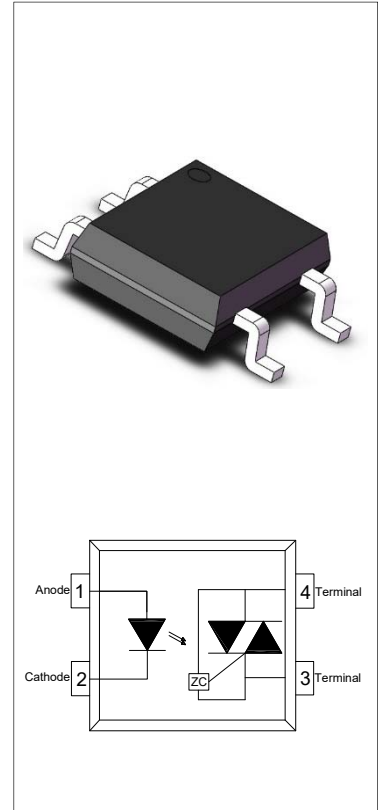

MAIN FEATURES

- High isolation 3750 VRMS
- DC input with zero-crossing photo triac output
- Operating temperature range -55 °C to 110 °C
- REACH & RoHS compliance
- HBM: H3A ; MM: M4; CDM: C3
- CQC approved
- VDE approved
- UL approved

ABSOLUTE MAXIMUM RATINGS (Temperature=25°C)

| Parameter | | Symbol | Value | Unit | |
|--------------------------|---|---------------------|-------------------|------|---|
| Input | Forward Current | I _F | 50 | mA | |
| | Peak Forward Current | I _{FP} | 1 ^① | A | |
| | Reverse Voltage | V _R | 6 | V | |
| | Power Dissipation | P _D | 75 | mW | |
| Output | Off-state Output Terminal Voltage | V _{OFF} | JOCSZ21X | 600 | V |
| | | | JOCSZ31X | 800 | |
| | Peak On-state Current (100μs pulse, 120 pps) | I _{TP} | 2 | A | |
| | On-state RMS Current | I _{T(RMS)} | 100 | mA | |
| | Peak Repetitive Surge Current (P _W =10 ms) | I _{TSM} | 1.2 | A | |
| Output Power Dissipation | | P _O | 250 | mW | |
| Total Power Dissipation | | P _{tot} | 325 | mW | |
| Isolation Voltage | | V _{iso} | 3750 ^② | Vrms | |

| | | | |
|--|-----------|---------|----|
| Operating Temperature | T_{opr} | -55~110 | °C |
| Junction Temperature | T_j | 125 | °C |
| Storage Temperature | T_{stg} | -55~125 | °C |
| Soldering Temperature | T_{sol} | 260 | °C |
| Peak pulse voltage ($T_j=25^{\circ}\text{C}$; non-repetitive,off-state) | V_{pp} | 1 | kV |

NOTE1: 100μs pulse, 100Hz frequency

NOTE2: AC for 1minute, R.H.=40~60%

ELECTRICAL CHARACTERISTICS (Temperature=25°C)

| Parameter | | Symbol | Condition | Min. | Typ. | Max. | Unit |
|-------------------------------|--|----------------------|---|-------------------|--|------------------|------|
| Input | Forward Voltage | V_F | $I_F=10\text{mA}$ | - | 1.2 | 1.5 | V |
| | Reverse Current | I_R | $V_R=6\text{V}$ | - | - | 1 | μA |
| | Input Capacitance | C_{in} | $V=0, f=1\text{kHz}$ | - | 10 | - | pF |
| Output | Peak Off-state Current, Either Direction | I_{OFF} | $V_{OFF}=\text{Rated } V_{OFF}$ $I_F=0$ | - | - | 100 ^③ | nA |
| | Peak On-state Voltage, Either Direction | V_{TM} | $I_{TM}=100\text{mA}$ | - | 1.8 | 2.5 | V |
| | Critical Rate of Rise of Off-state voltage | dV/dt | $V_{PEAK}=\text{Rated } V_{PEAK}$ $I_F=0$ | 2000 ^④ | - | - | V/μs |
| Transfer Characteristics | LED Trigger Current | JOCSZ21A JOCSZ31A | Terminal Voltage=3V $I_{TM}=100\text{mA}$ | - | - | 10 | mA |
| | | JOCSZ21B JOCSZ31B | | - | - | 5 | |
| | | JOCSZ21C JOCSZ31C | | - | - | 3 | |
| | | Holding Current | | I_H | $I_{TM}=2\text{mA},$ $I_F=\text{Rated } I_{FT}$ | - | |
| | Isolation Resistance | R_{ISO} | DC500V 40~60%R.H. | 10^{12} | 10^{14} | - | Ω |
| | Floating Capacitance | C_{IO} | $V=0,$ $f=1\text{MHz}$ | - | 10 | - | pF |
| | Response Time | t_{on} | $V_D=6\text{V},$ $R_L=100\Omega,$ $I_F=20\text{mA}$ | - | 15 | 50 | μs |
| Zero-Crossing Characteristics | Inhibit Voltage | V_{IH} | $I_F=\text{Rated } I_{FT}$ | - | - | 20 | V |
| | Leakage in Inhibited State | I_{OFF2} | $I_F=\text{Rated } I_{FT}$ $V_{OFF}=\text{Rated } V_{OFF}$ | - | - | 5 | mA |

NOTE3: Test voltage must be applied within dV/dt ratings.

NOTE4: Refer to Fig.14 & Fig.15

ORDERING INFORMATION

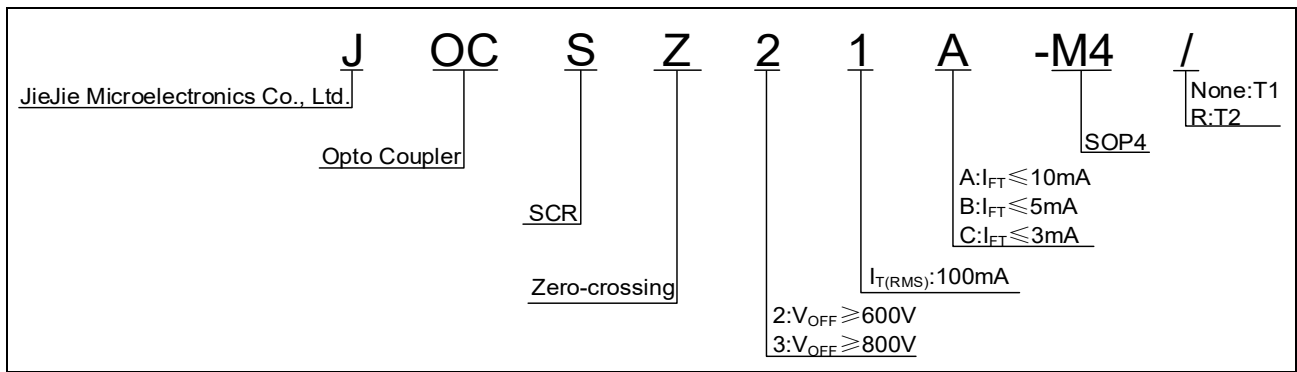

| Packing Quantity | |
|------------------|-----------------|
| Option | Quantity |
| None/R | 3000 Units/Reel |

MARKING

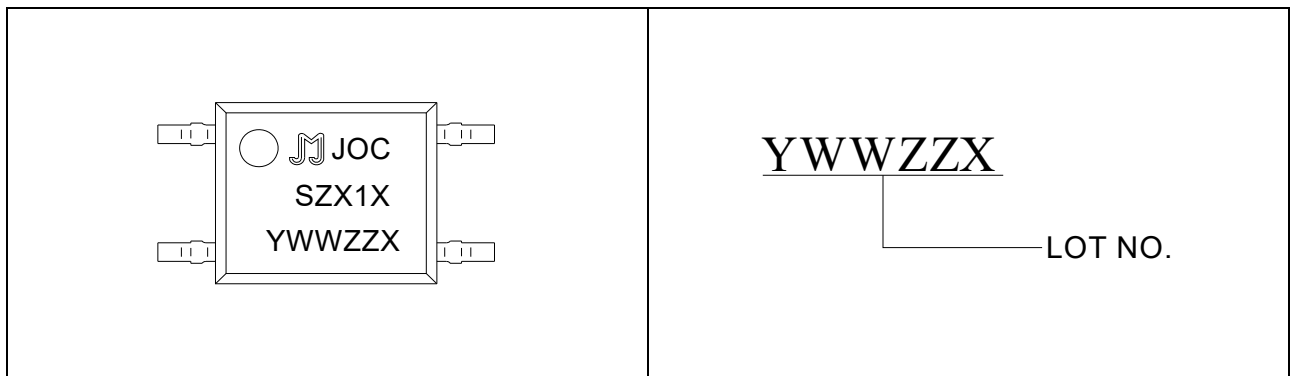

Characteristics Curves

FIG.1: Max. Allowable LED Forward Current vs. Ambient Temperature

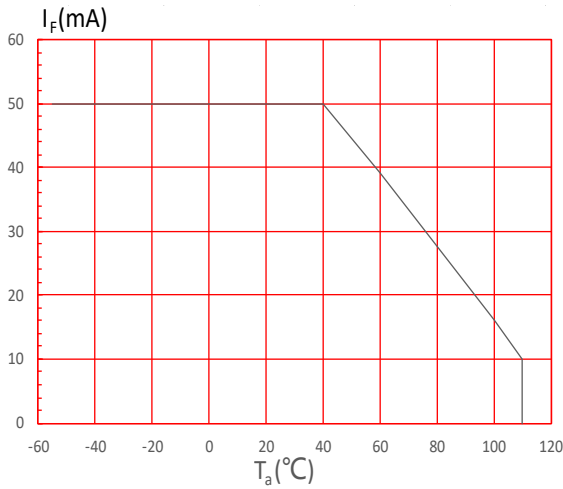

FIG.2: On-state Terminal Current vs. Ambient Temperature

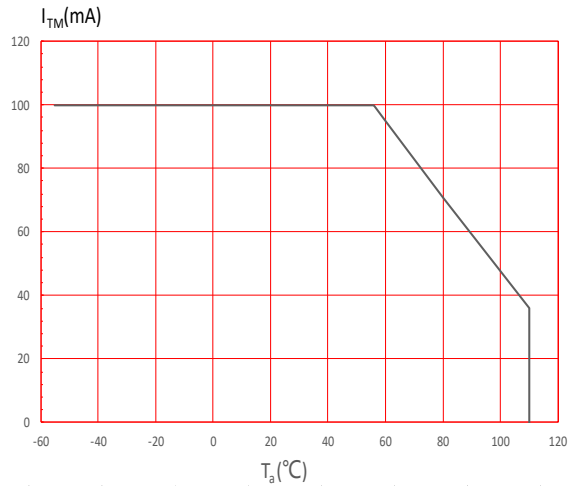

FIG.3: Forward Current vs. Forward Voltage

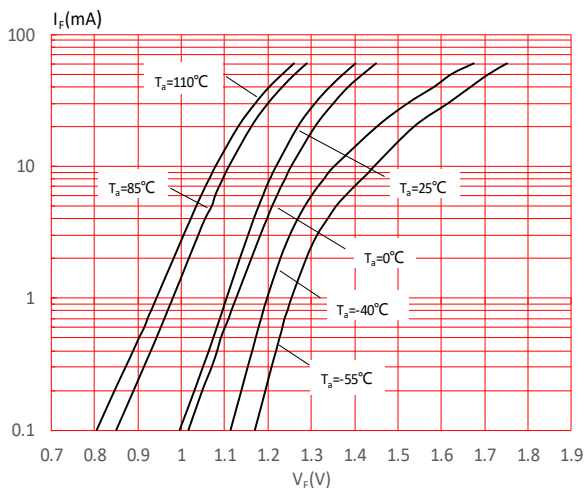

FIG.4: Normalized Off-state Terminal Current vs. Ambient Temperature

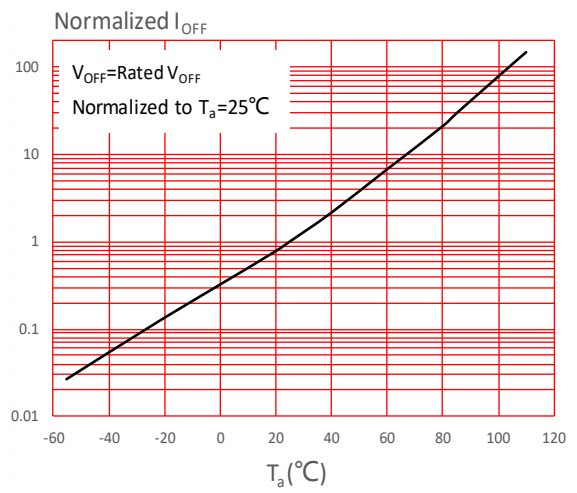

FIG.5: Normalized Off-state Terminal Voltage vs. Ambient Temperature

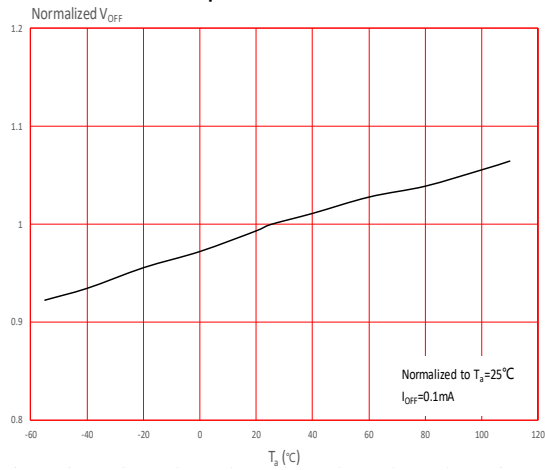

FIG.6: Normalized Trigger Current vs. Ambient Temperature

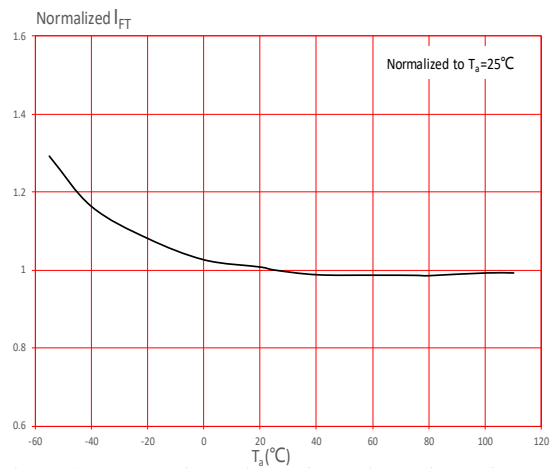

FIG.7: Normalized On-state Terminal Voltage vs. Ambient Temperature

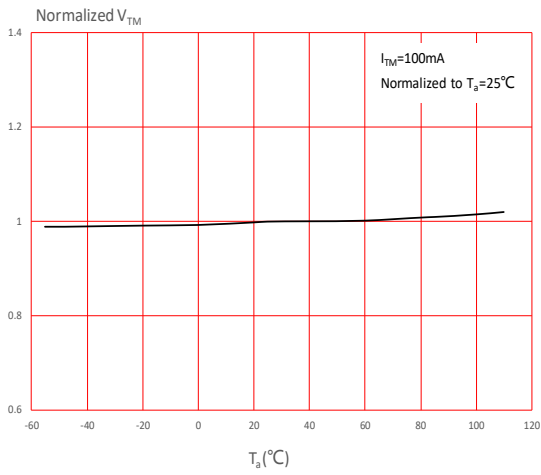

FIG.8: On-state Terminal Voltage vs. On-state Terminal Current

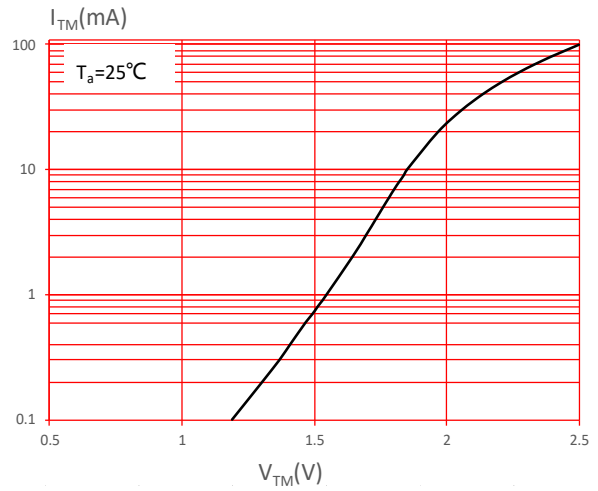

FIG.9: Normalized Holding Current vs. Ambient Temperature

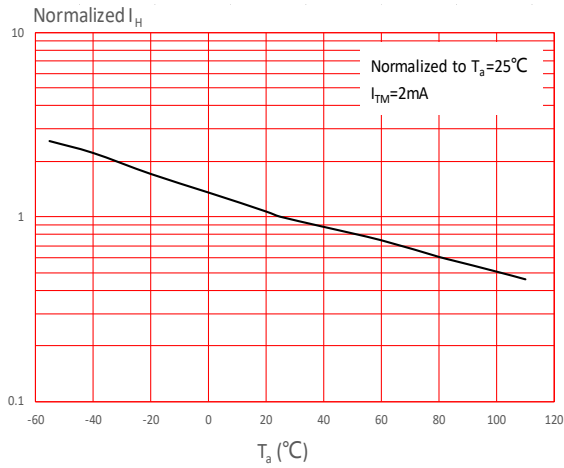

FIG.10: Normalized Leakage in Inhibit State vs. Ambient Temperature

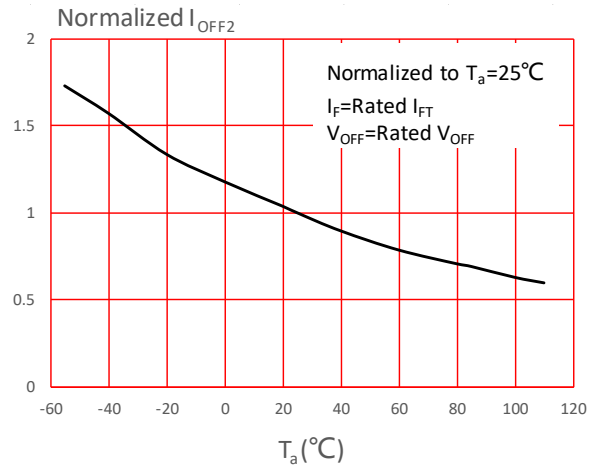
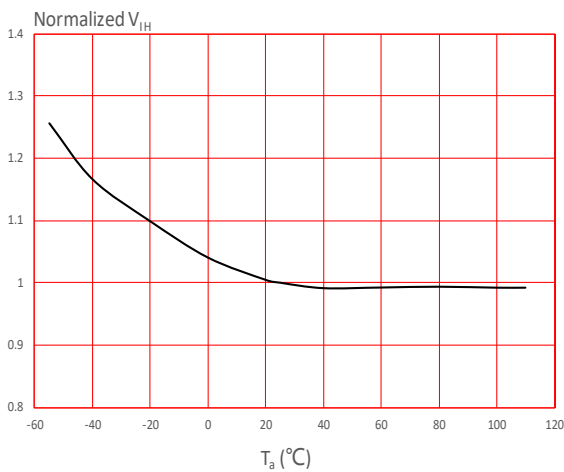

FIG.11: Normalized Inhibit Voltage vs. Ambient Temperature



TEST CIRCUITS

FIG.12: Test Circuits of Turn On Time

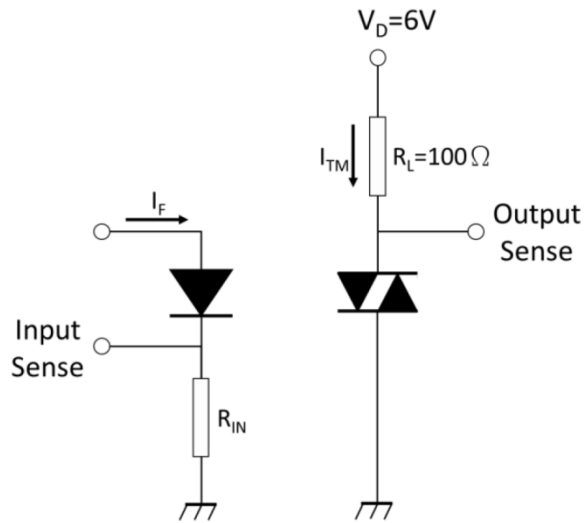

FIG.13: Waveforms of Turn On Time



Fig.14: Test Circuits of dV/dt

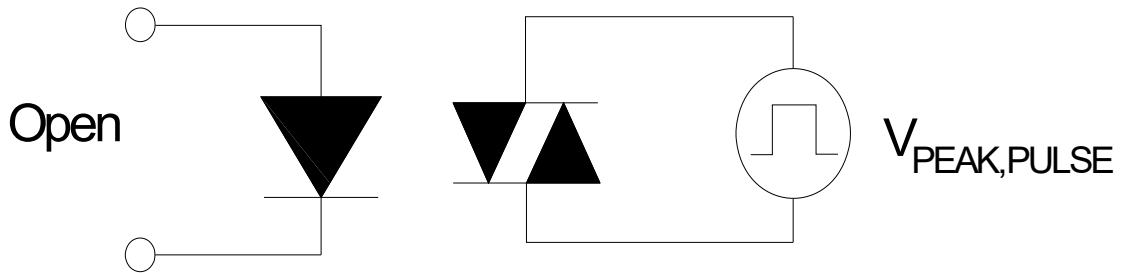

Fig.15: Waveforms of dV/dt

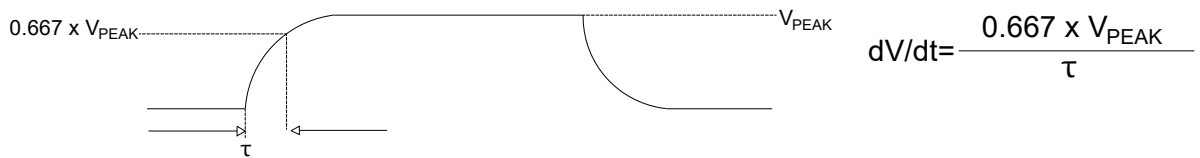
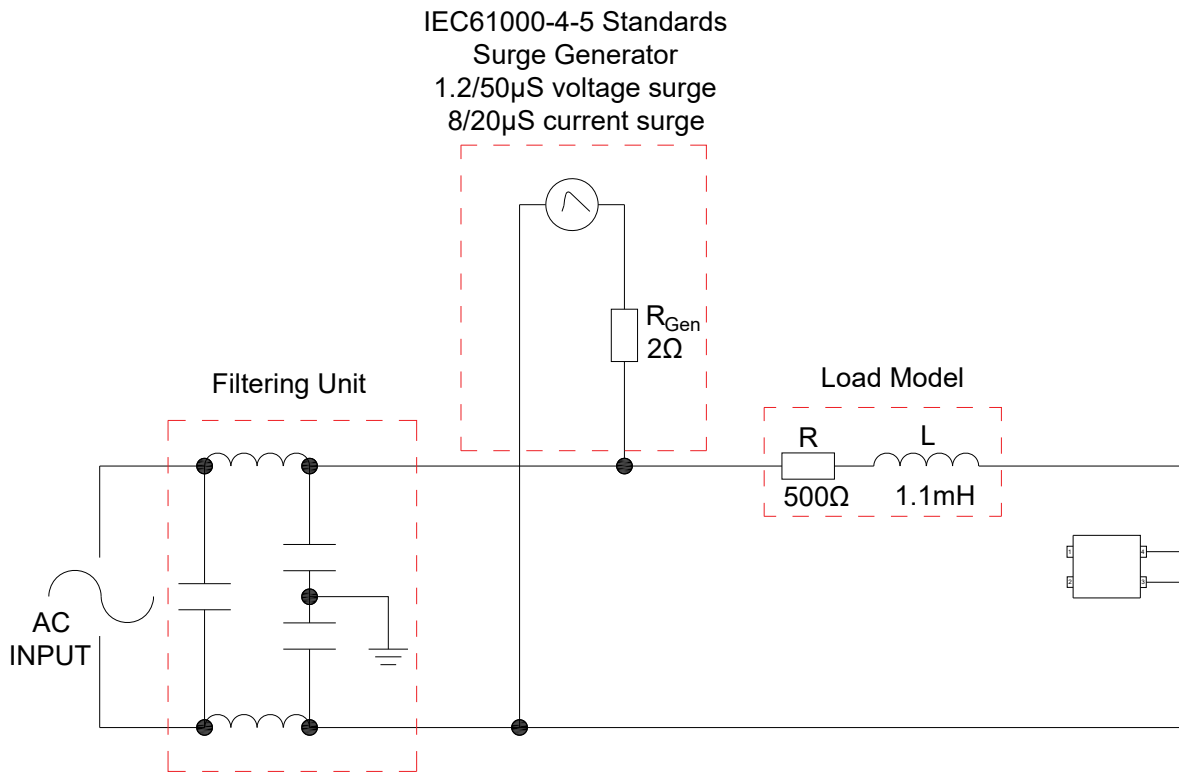
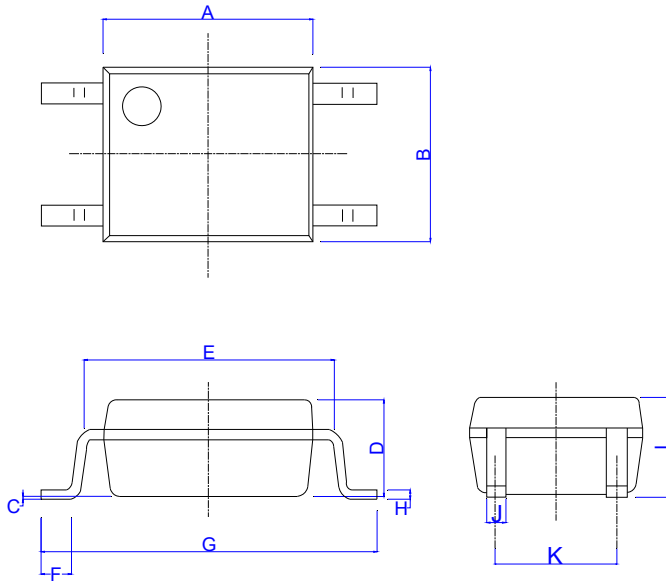

FIG.16: Test circuit for inductive and resistive loads to IEC-61000-4-5 standards



Package Dimension (Unit: mm)



| Ref. | Dimensions | | | | | |
|------|-------------|------|------|--------|------|-------|
| | Millimeters | | | Inches | | |
| | Min. | Typ. | Max. | Min. | Typ. | Max. |
| A | 4.40 | | 4.80 | 0.173 | | 0.189 |
| B | 3.60 | | 4.20 | 0.142 | | 0.165 |
| C | 0.00 | | 0.20 | 0.000 | | 0.008 |
| D | 1.90 | | 2.30 | 0.075 | | 0.091 |
| E | 5.00 | | 5.60 | 0.197 | | 0.220 |
| F | 0.34 | | 0.94 | 0.013 | | 0.037 |
| G | 6.70 | | 7.30 | 0.264 | | 0.287 |
| H | 0.10 | | 0.30 | 0.004 | | 0.012 |
| I | 2.00 | | 2.40 | 0.079 | | 0.094 |
| J | 0.25 | | 0.55 | 0.010 | | 0.022 |
| K | 2.29 | | 2.79 | 0.090 | | 0.110 |

RECOMMENDED SOLDER MASK (Dimensions in mm unless otherwise stated)

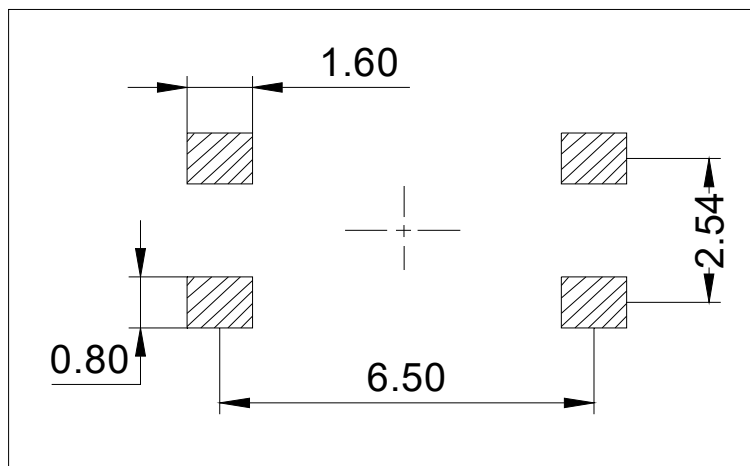

CARRIER TAPE SPECIFICATIONS (Dimensions in mm unless otherwise stated)

Option None

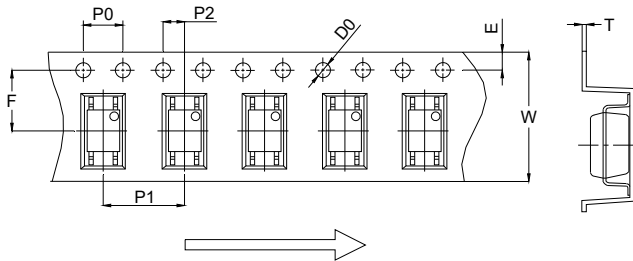

| Ref. | Dimensions | | | | | |
|------|-------------|-------|-------|--------|-------|-------|
| | Millimeters | | | Inches | | |
| | Min. | Typ. | Max. | Min. | Typ. | Max. |
| D0 | | 1.50 | 1.60 | | 0.059 | 0.063 |
| P0 | 3.90 | 4.00 | 4.10 | 0.154 | 0.157 | 0.161 |
| P1 | 7.90 | 8.00 | 8.10 | 0.311 | 0.315 | 0.319 |
| P2 | 1.90 | 2.00 | 2.10 | 0.075 | 0.079 | 0.083 |
| E | 1.65 | 1.75 | 1.85 | 0.065 | 0.069 | 0.073 |
| F | 4.40 | 4.50 | 4.60 | 0.173 | 0.177 | 0.181 |
| T | 0.25 | 0.30 | 0.35 | 0.010 | 0.012 | 0.014 |
| W | 11.90 | 12.00 | 12.30 | 0.469 | 0.472 | 0.484 |

Option R

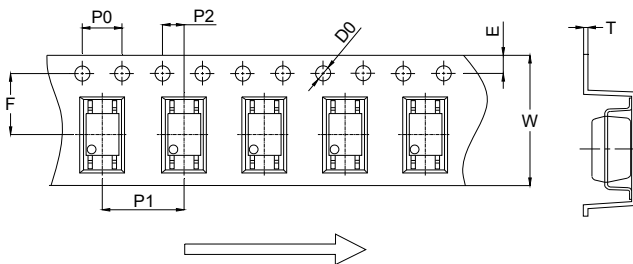

| Ref. | Dimensions | | | | | |
|------|-------------|-------|-------|--------|-------|-------|
| | Millimeters | | | Inches | | |
| | Min. | Typ. | Max. | Min. | Typ. | Max. |
| D0 | | 1.50 | 1.60 | | 0.059 | 0.063 |
| P0 | 3.90 | 4.00 | 4.10 | 0.154 | 0.157 | 0.161 |
| P1 | 7.90 | 8.00 | 8.10 | 0.311 | 0.315 | 0.319 |
| P2 | 1.90 | 2.00 | 2.10 | 0.075 | 0.079 | 0.083 |
| E | 1.65 | 1.75 | 1.85 | 0.065 | 0.069 | 0.073 |
| F | 4.40 | 4.50 | 4.60 | 0.173 | 0.177 | 0.181 |
| T | 0.25 | 0.30 | 0.35 | 0.010 | 0.012 | 0.014 |
| W | 11.90 | 12.00 | 12.30 | 0.469 | 0.472 | 0.484 |

REFLOW INFORMATION



| Profile Feature | Sn-Pb Assembly Profile | Pb-Free Assembly Profile |
|---|------------------------|--------------------------|
| Temperature Min. (T _{smin}) | 100 | 150°C |
| Temperature Max. (T _{smax}) | 150 | 200°C |
| Time (t _s) from (T _{smin} to T _{smax}) | 60-120 seconds | 60-120 seconds |
| Ramp-up Rate (t _L to t _P) | 3°C/second max. | 3°C/second max. |
| Liquidus Temperature (T _L) | 183°C | 217°C |
| Time (t _L) Maintained Above (T _L) | 60-150 seconds | 60-150 seconds |
| Peak Body Package Temperature | 235°C+0°C/-5°C | 260°C+0°C/-5°C |
| Time (t _P) within 5°C of 260°C | 20 seconds | 30 seconds |
| Ramp-down Rate (T _P to T _L) | 6°C/second max. | 6°C/second max. |
| Time 25°C to Peak Temperature | 6 minutes max. | 8 minutes max. |

Note:

1. Reflow soldering is recommended at the temperatures and times shown, no more than three times.
2. Avoid direct contact between the epoxy body and any tools or surfaces exceeding its maximum storage temperature.
3. Application of pressure on the epoxy body is prohibited at elevated temperatures. In specific scenarios, any applied force must not exceed 2.5N.
4. Ensure the component has cooled to ambient temperature before proceeding with any subsequent manufacturing steps.
5. The component has a shelf life of one year when stored under standard conditions.
6. Recommend storage Temp.: 0~40°C;
Recommend storage humidity: <60%;
MSL level: MSL 1

Information furnished in this document is believed to be accurate and reliable. However, Jiangsu JieJie Microelectronics Co., Ltd. assumes no responsibility for the consequences of use without consideration for such information nor use beyond it. Information mentioned in this document is subject to change without notice, apart from that when an agreement is signed, Jiangsu JieJie complies with the agreement.

Products and information provided in this document have no infringement of patents. Jiangsu JieJie assumes no responsibility for any infringement of other rights of third parties which may result from the use of such products and information. This document supersedes and replaces all information previously supplied.

 is a registered trademark of Jiangsu JieJie Microelectronics Co., Ltd.

Copyright © 2026 Jiangsu JieJie Microelectronics Co., Ltd. All rights reserved.