

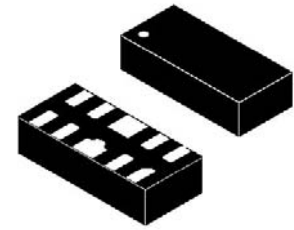

FEATURES

- ✧ Solid-state silicon-avalanche technology
- ✧ Up to four I/O lines of protection
- ✧ Low operating voltage:3.3V
- ✧ Ultra low capacitance: 0.25pF typical(I/O to I/O)
- ✧ Low operating and clamping voltage
- ✧ Low leakage current
- ✧ RoHS compliant



DFN2510-10L

MAIN APPLICATIONS

- ✧ Digital visual interface(DVI)
- ✧ Display port TM interface
- ✧ MDDI ports
- ✧ PCI express
- ✧ SATA interfaces
- ✧ High definition multi-media interface(HDMI)

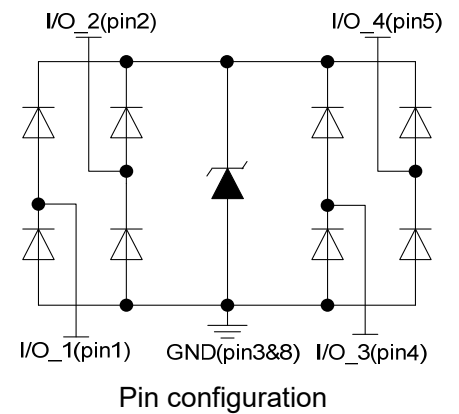

PROTECTION SOLUTION TO MEET

- ✧ IEC61000-4-2 (ESD) $\pm 10\text{kV}$ (air), $\pm 10\text{kV}$ (contact)
- ✧ IEC61000-4-4 (EFT) 40A(5/50ns)
- ✧ IEC61000-4-5 (Lightning) 7A (8/20 μs)

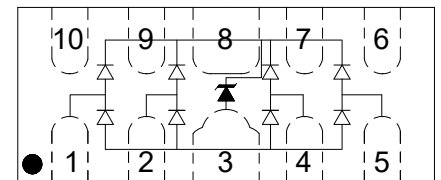

MECHANICAL CHARACTERISTICS

- ✧ DFN2510-10L package
- ✧ Molding compound flammability rating: UL 94V-0
- ✧ Quantity per reel: 3,000pcs
- ✧ Lead finish: lead free
- ✧ Marking code: 3324P

ABSOLUTE MAXIMUM RATINGS ($T_A=25^{\circ}\text{C}$, RH=45%-75%, unless otherwise noted)

Parameter	Symbol	Value	Unit
Peak pulse power dissipation at 8/20 μs waveform	P_{PP}	70	W
ESD per IEC 61000-4-2 (Air) ESD per IEC 61000-4-2 (Contact)	V_{ESD}	± 10 ± 10	kV
Lead soldering temperature	T_L	260 (10 sec.)	$^{\circ}\text{C}$
Operating junction temperature range	T_J	-55 to +125	$^{\circ}\text{C}$
Storage temperature range	T_{STG}	-55 to +150	$^{\circ}\text{C}$

ELECTRICAL CHARACTERISTICS ($T_A=25^{\circ}\text{C}$)

Parameter	Symbol	Conditions	Min	Typ	Max	Unit
Reverse working voltage	V_{RWM}	I/O to GND			3.3	V
Reverse breakdown voltage	V_{BR}	I/O to GND@ $I_T=1\text{mA}$	4		10	V
Reverse leakage current	I_R	I/O to GND @ $V_{RWM}=3.3\text{V}$			0.1	μA
Clamping voltage	$V_C^{①}$	$I_{PP}=4\text{A}$, $t_P=100\text{ns}$		6.5		V
		$I_{PP}=16\text{A}$, $t_P=100\text{ns}$		9.0		V
Dynamic resistance	$R_{DYN}^{①}$	$t_P=100\text{ns}$		0.23		Ω
Clamping voltage	$V_C^{②}$	$I_{PP}=1\text{A}$, $t_P=8/20\mu\text{s}$		5.5	6.5	V
		$I_{PP}=5\text{A}$, $t_P=8/20\mu\text{s}$		7.5	8.5	V
		$I_{PP}=7\text{A}$, $t_P=8/20\mu\text{s}$		9	10.5	V
Junction capacitance	C_J	$V_{RWM}=0\text{V}$, $f=1\text{MHz}$ I/O pin to GND		0.5	0.6	pF
		$V_{RWM}=0\text{V}$, $f=1\text{MHz}$ Between I/O pins		0.25	0.35	pF

① TLP parameter: $Z_0=50\Omega$, $t_P=100\text{ns}$, $t_r=2\text{ns}$, averaging window from 60ns to 80ns. R_{DYN} is calculated from 4A to 16A.

② Non-repetitive current pulse, according to IEC61000-4-5.

RATINGS AND V-I CHARACTERISTICS CURVES (T_A=25°C, unless otherwise noted)

FIG.1: V- I curve characteristics (Uni-directional)

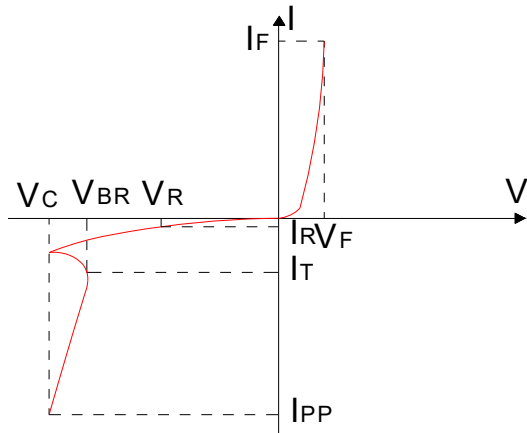

FIG.2: Pulse waveform (8/20μs)

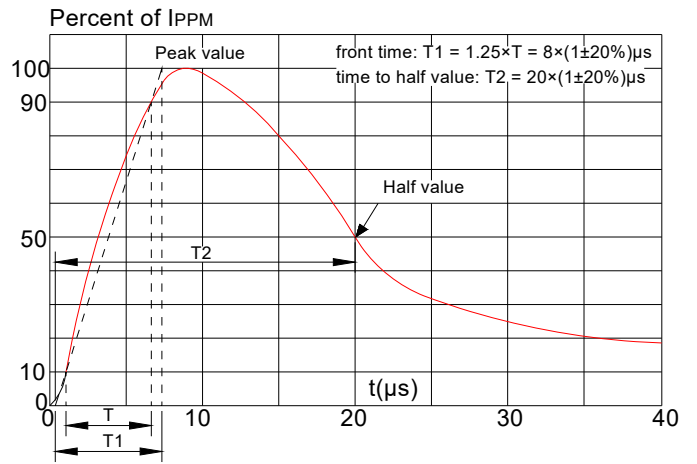

FIG.3: Pulse derating curve

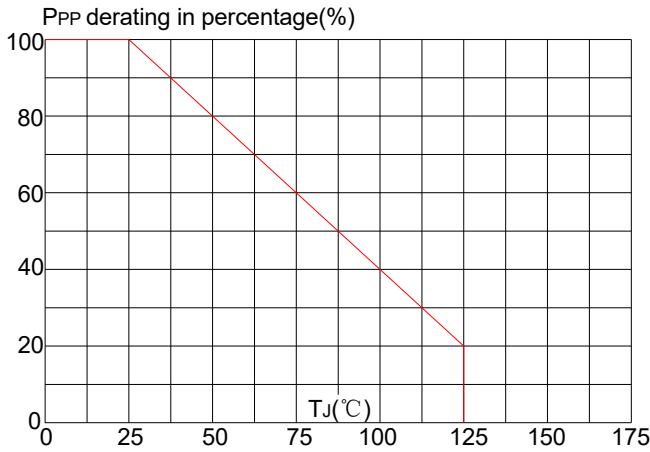

FIG.4: ESD clamping (10KV contact)

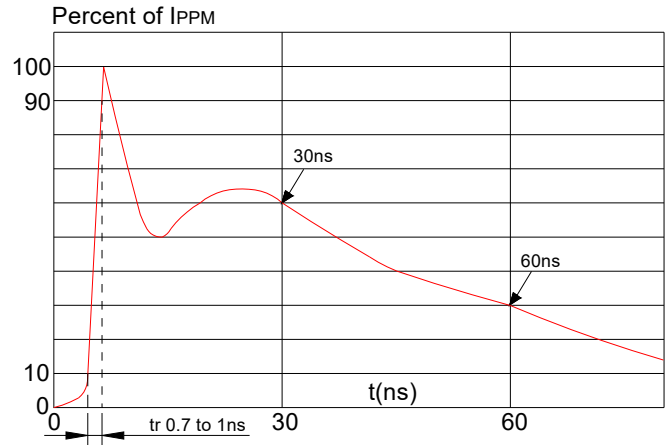
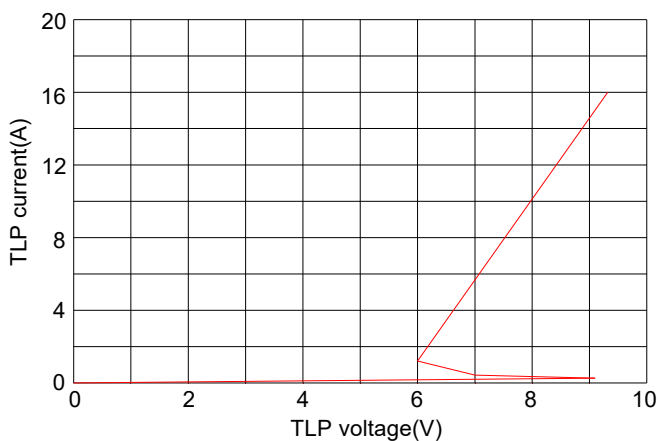
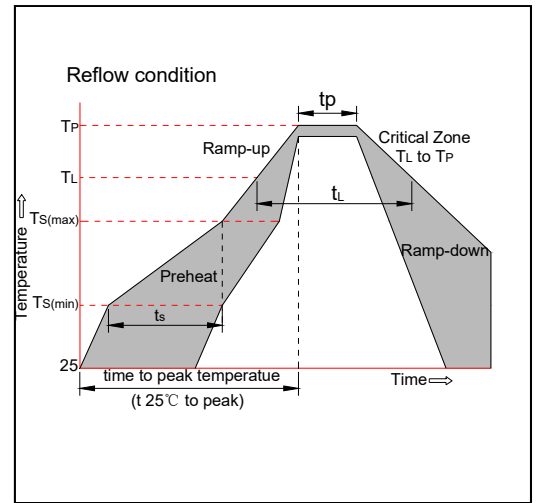

FIG.5: TLP testing of I/O to GND



SOLDERING PARAMETERS

Reflow Condition		Pb-Free assembly (see figure at right)
Pre Heat	-Temperature Min ($T_{s(min)}$)	+150°C
	-Temperature Max($T_{s(max)}$)	+200°C
	-Time (Min to Max) (ts)	60-180 secs.
Average ramp up rate (Liquidus Temp (T_L) to peak)		3°C/sec. Max
$T_{s(max)}$ to T_L - Ramp-up Rate		3°C/sec. Max
Reflow	-Temperature(T_L)(Liquidus)	+217°C
	-Temperature(t_L)	60-150 secs.
Peak Temp (T_P)		+260(+0/-5)°C
Time within 5°C of actual Peak Temp (t_p)		20-40secs.
Ramp-down Rate		6°C/sec. Max
Time 25°C to Peak Temp (T_P)		8 min. Max
Do not exceed		+260°C



PACKAGE MECHANICAL DATA

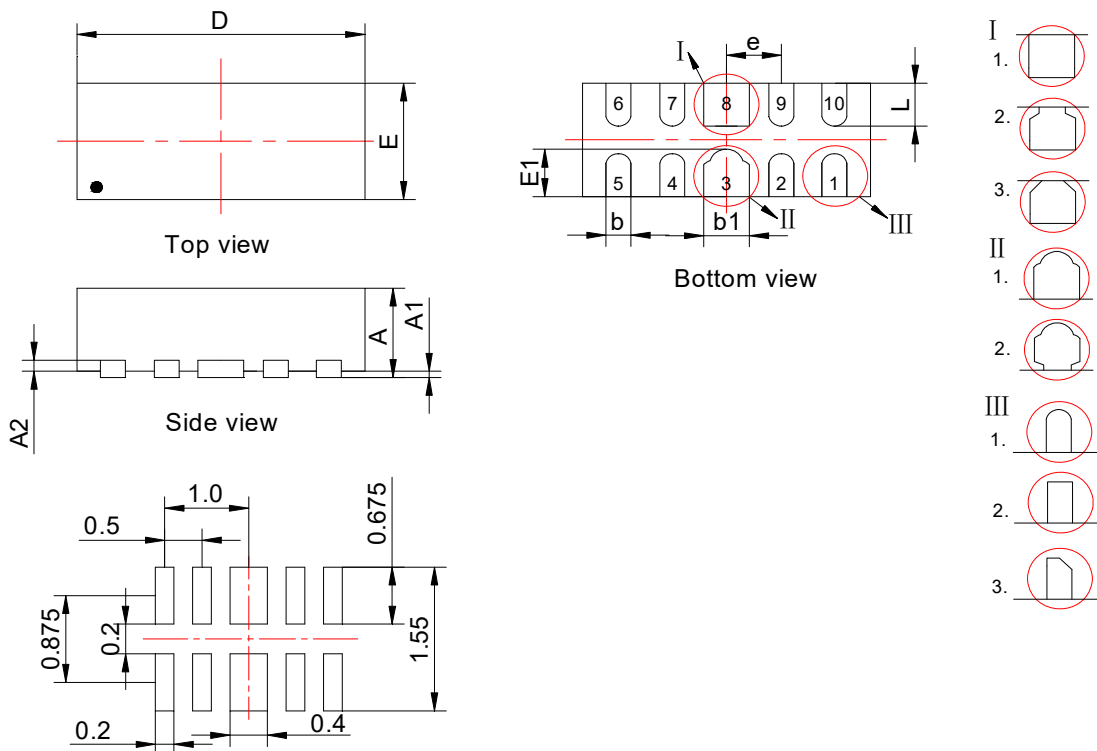

Recommended soldering footprint

Symbol	Millimeters			Inches		
	Min.	Typ.	Max.	Min.	Typ.	Max.
A	0.46	0.53	0.60	0.018	0.021	0.024
A1	0.00	0.02	0.05	0.000	0.001	0.002
A2	0.15Ref.			0.006Ref.		
b	0.15	0.20	0.25	0.006	0.008	0.010
b1	0.35	0.40	0.45	0.014	0.016	0.018
D	2.40	2.50	2.60	0.094	0.098	0.102
E	0.90	1.00	1.10	0.035	0.039	0.043
E1	0.30	0.40	0.56	0.012	0.016	0.022
e	0.50BSC			0.020BSC		
L	0.30	0.40	0.45	0.012	0.016	0.018

TAPE AND REEL INFORMATION-DFN2510-10L

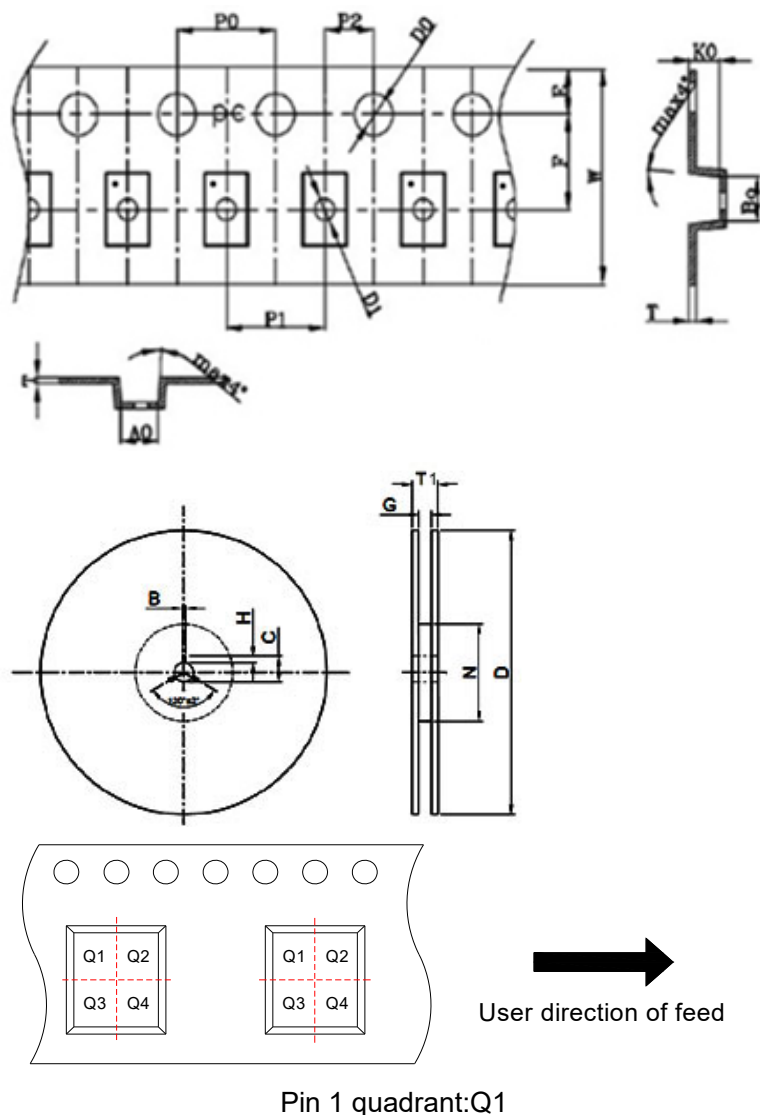

Symbol	Dimensions	
	Millimeters	Inches
	Typ.	Typ.
A0	1.20	0.047
B0	2.75	0.108
K0	0.70	0.028
P0	4.00	0.157
P1	4.00	0.157
P2	2.00	0.079
T	0.20	0.008
E	1.75	0.069
F	3.50	0.138
D0	1.55	0.061
D1	0.60	0.024
W	8.0	0.315
B	2.0	0.079
H	4.0	0.157
C	13.0	0.512
G	8.4	0.331
T1	14.9(max)	0.587(max)
N	60.0	2.362
D	178.0	7.000

ORDERING INFORMATION

Part Number	Package	Quantity Per Reel (PCS)	Reel Size
JEU3324P	DFN2510-10L	3,000	7 Inch

MARKING CODE

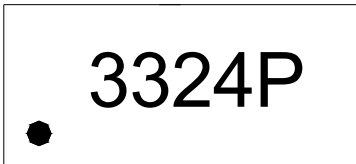
Part Number	Marking Code
JEU3324P	

JieJie products are not designed for, and shall not be used for, any purpose (including, without limitation, automotive, military, aerospace, medical, life-saving, life-sustaining or nuclear facility applications, devices intended for surgical implant into the body, or any other application in which the failure or lack of desired operation of the product may result in personal injury, death, or property damage) other than those expressly set forth in applicable JieJie product documentation. Warranties granted by JieJie shall be deemed void for products used for any purpose not expressly set forth in applicable JieJie documentation. JieJie shall not be liable for any claims or damages arising out of products used in applications not expressly intended by JieJie as set forth in applicable JieJie documentation. The sale and use of JieJie products is subject to JieJie terms and conditions of sale, unless otherwise agreed by JieJie.

Information furnished in this document is believed to be accurate and reliable. However, Jiangsu JieJie Microelectronics Co., Ltd. assumes no responsibility for the consequences of use without consideration for such information nor use beyond it.

Information mentioned in this document is subject to change without notice, apart from that when an agreement is signed, Jiangsu JieJie complies with the agreement.

Products and information provided in this document have no infringement of patents. Jiangsu JieJie assumes no responsibility for any infringement of other rights of third parties which may result from the use of such products and information.

This document is the 1.3rd version which is made in 3-Dec.-2025. This document supersedes and replaces all information previously supplied.

 is a registered trademark of Jiangsu JieJie Microelectronics Co., Ltd.

Copyright ©2025 Jiangsu JieJie Microelectronics Co., Ltd. Printed All rights reserved.