



FEATURES

- ✧ Solid-state silicon technology
- ✧ Low clamping voltage and low leakage current
- ✧ Working voltage: 7V
- ✧ Ultra-low capacitance
- ✧ RoHS compliant

MAIN APPLICATIONS

- ✧ Cellular handsets
- ✧ USB V_{BUS} and CC line protection
- ✧ Microphone line protection
- ✧ GPIO protection

PROTECTION SOLUTION TO MEET

- ✧ IEC61000-4-2 (ESD) ±30kV (air), ±30kV (contact)
- ✧ IEC61000-4-4 (EFT) 40A (5/50ns)
- ✧ IEC61000-4-5 (Lightning) 6A (8/20μs)

MECHANICAL CHARACTERISTICS

- ✧ DFN1006-2L package
- ✧ Molding compound flammability rating: UL 94V-0
- ✧ Marking code: 7A
- ✧ Quantity per reel:10,000pcs
- ✧ Lead finish: lead free

ABSOLUTE MAXIMUM RATINGS(T_A=25°C, RH=45%-75%, unless otherwise noted)

Parameter	Symbol	Value	Unit
Peak pulse power dissipation at 8/20μs waveform	P _{PP}	84	W
ESD per IEC 61000-4-2 (Air)	V _{ESD}	+/- 30	kV
ESD per IEC 61000-4-2 (Contact)		+/- 30	
Lead soldering temperature	T _L	260 (10 sec.)	°C
Operating junction temperature range	T _J	-55 to +125	°C
Storage temperature range	T _{STG}	-55 to +150	°C



DFN1006-2L(Bottom view)

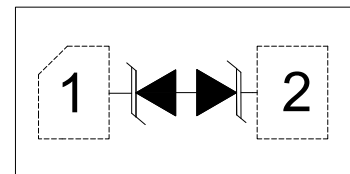

Pin Configuration(Top view)

ELECTRICAL CHARACTERISTICS($T_A=25^{\circ}\text{C}$)

Parameter	Symbol	Conditions	Min	Typ	Max	Unit
Reverse working voltage	V_{RWM}				7	V
Reverse breakdown voltage	V_{BR}	$I_T=1\text{mA}$	7.2		10.5	V
Reverse holding voltage	V_H	$I_H=50\text{mA}$	7.2		10.5	V
Reverse leakage current	I_R	$V_{RWM}=7\text{V}$			0.1	μA
Peak pulse current	I_{PP}	$t_P=8/20\mu\text{s}$			6	A
Clamping voltage	$V_C^{①}$	$I_{PP}=16\text{A}, t_P=100\text{ns}$		12		V
Dynamic resistance	$R_{DYN}^{①}$			0.28		Ω
Clamping voltage	$V_C^{②}$	$V_{ESD}=8\text{kV}$		12		V
Clamping voltage	$V_C^{③}$	$I_{PP}=1\text{A}, t_P=8/20\mu\text{s}$		9	11	V
		$I_{PP}=6\text{A}, t_P=8/20\mu\text{s}$		12	14	V
Junction capacitance	C_J	$V_{RWM}=0\text{V}, f=1\text{MHz}$		13	15	pF
		$V_{RWM}=2.5\text{V}, f=1\text{MHz}$		10	13	pF

① TLP parameter: $Z_0=50\Omega, t_P=100\text{ns}, t_r=2\text{ns}$, averaging window from 60ns to 80ns. R_{DYN} is calculated from 4A to 16A.

② Contact discharge mode, according to IEC61000-4-2.

③ Non-repetitive current pulse, according to IEC61000-4-5.

RATINGS AND V-I CHARACTERISTICS CURVES (T_A=25°C, unless otherwise noted)

FIG.1: V- I curve characteristics (Bi-directional)

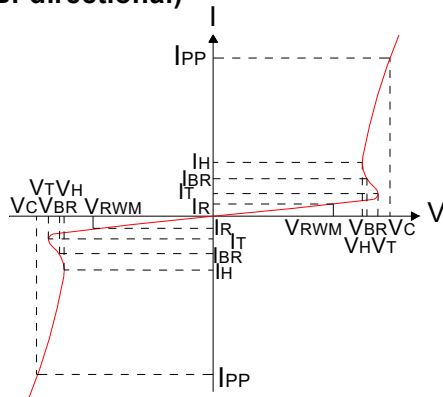

FIG.2: Pulse waveform (8/20μs)

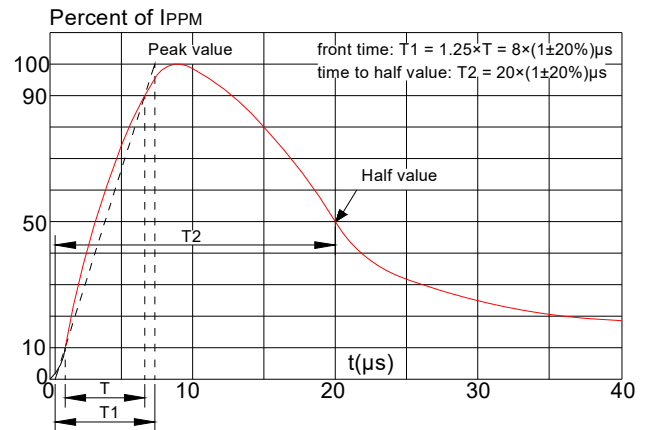

FIG.3: Pulse derating curve

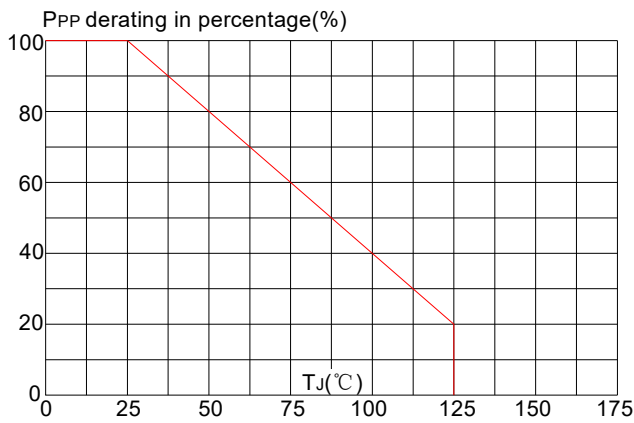

FIG.4: ESD clamping (30kV contact)

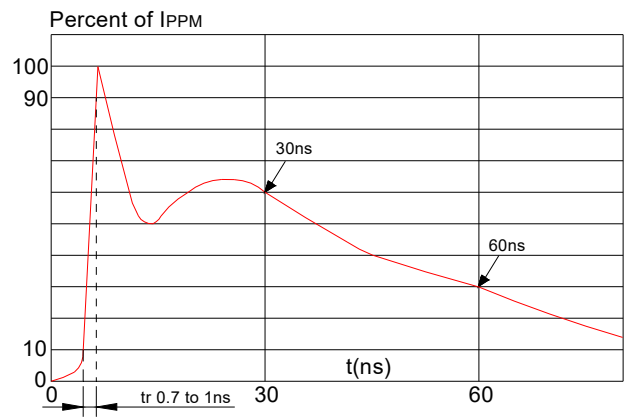

FIG.5: Clamping voltage vs. peak pulse current

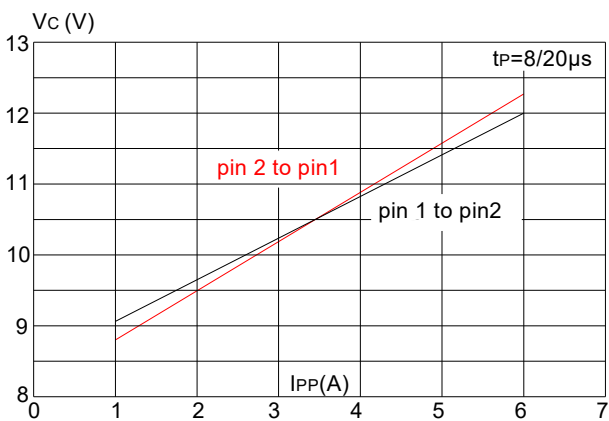
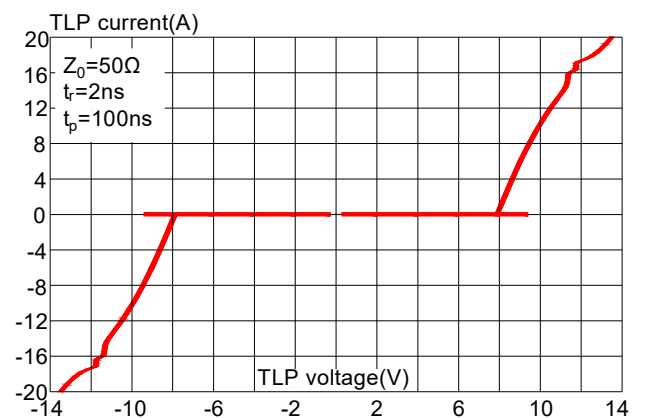
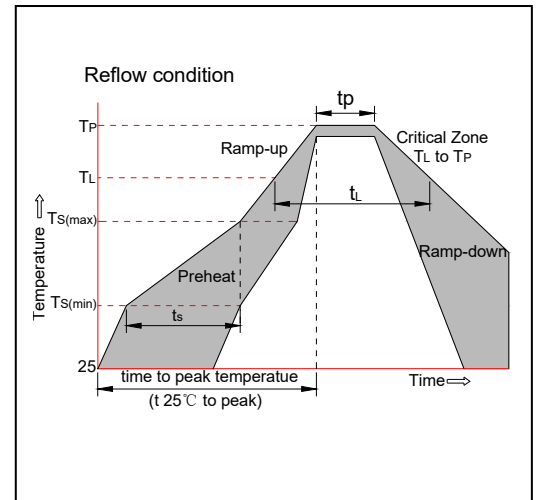

FIG.6: TLP Measurement



SOLDERING PARAMETERS

Reflow Condition		Pb-Free assembly (see figure at right)
Pre Heat	-Temperature Min ($T_{s(min)}$)	+150°C
	-Temperature Max($T_{s(max)}$)	+200°C
	-Time (Min to Max) (t_s)	60-180 secs.
Average ramp up rate (Liquidus Temp (T_L)to peak)		3°C/sec. Max
$T_{s(max)}$ to T_L - Ramp-up Rate		3°C/sec. Max
Reflow	-Temperature(T_L)(Liquidus)	+217°C
	-Temperature(t_L)	60-150 secs.
Peak Temp (T_P)		+260(+0/-5)°C
Time within 5°C of actual Peak Temp (t_p)		20-40secs.
Ramp-down Rate		6°C/sec. Max
Time 25°C to Peak Temp (T_P)		8 min. Max
Do not exceed		+260°C



PACKAGE MECHANICAL DATA

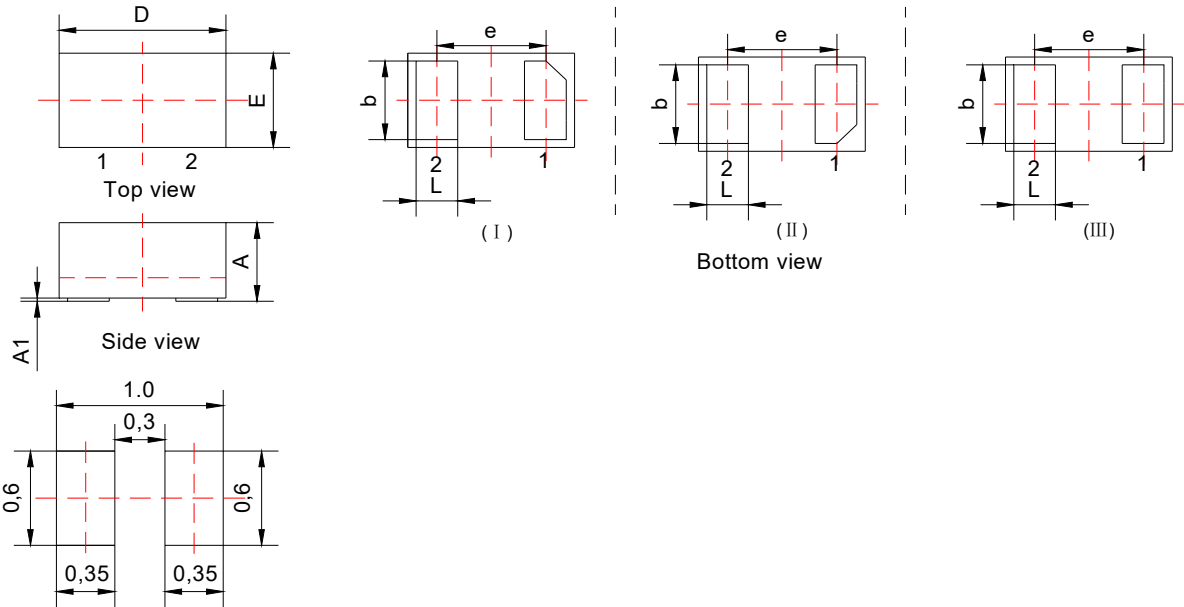

Recommended soldering footprint(mm)

Symbol	Millimeters			Inches		
	Min.	Typ.	Max.	Min.	Typ.	Max.
A	0.40	0.50	0.55	0.016	0.020	0.022
A1	0.00	0.02	0.05	0.000	0.001	0.002
b	0.45	0.50	0.55	0.018	0.020	0.022
D	0.95	1.00	1.05	0.037	0.039	0.041
e	0.65BSC			0.026BSC		
E	0.55	0.60	0.65	0.022	0.024	0.026
L	0.20	0.25	0.30	0.008	0.010	0.012

TAPE AND REEL INFORMATION-DFN1006-2L

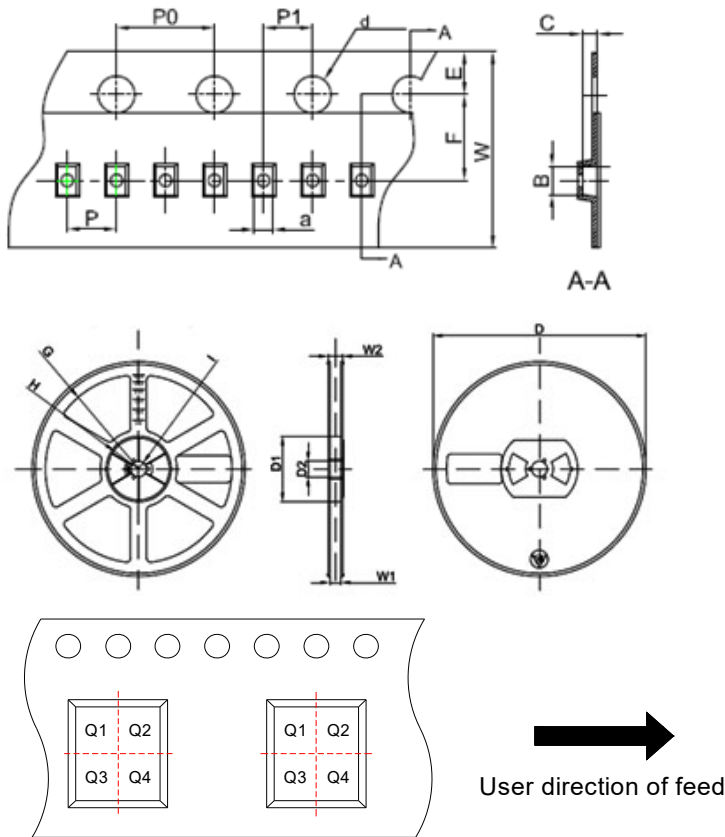

Pin 1 quadrant:Q1&Q2

Packaging Description:

DFN1006-2L parts are shipped in tape. The carrier tape is made from a dissipative(carbon filled) polycarbonate resin. The cover tape is a multilayer film(heat activated adhesive in nature)primarily composed of polyester film, adhesive layer, sealant, and anti-static sprayed agent. These reeled parts in standard option are shipped with 10,000units per 7" or 17.8cm diameter reel. The reels are clear in color and made of polystyrene plastic(anti-static

Symbol	Millimeters	Inches
	Typ.	Typ.
a	0.66	0.026
B	1.15	0.045
C	0.66	0.026
d	Φ1.50	Φ0.059
E	1.75	0.069
F	3.50	0.138
P0	4.00	0.157
P	2.00	0.079
P1	2.00	0.079
W	8.00	0.315
D	Φ178	Φ7.008
D1	54.40	2.142
D2	13.00	0.512
G	R78.00	R3.071
H	R25.60	R1.008
I	R6.50	R0.256
W1	9.50	0.374
W2	12.30	0.484

ORDERING INFORMATION

PART No.	PACKAGE TYPE	QUANTITY(PCS) REEL	DESCRIPTION
JEB07DFA	DFN1006-2L	10,000	7 inch reel pack

MARKING CODE

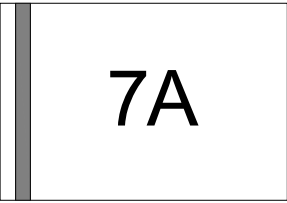
Part Number	Marking Code
JEB07DFA	

JieJie products are not designed for, and shall not be used for, any purpose (including, without limitation, automotive, military, aerospace, medical, life-saving, life-sustaining or nuclear facility applications, devices intended for surgical implant into the body, or any other application in which the failure or lack of desired operation of the product may result in personal injury, death, or property damage) other than those expressly set forth in applicable JieJie product documentation. Warranties granted by JieJie shall be deemed void for products used for any purpose not expressly set forth in applicable JieJie documentation. JieJie shall not be liable for any claims or damages arising out of products used in applications not expressly intended by JieJie as set forth in applicable JieJie documentation. The sale and use of JieJie products is subject to JieJie terms and conditions of sale, unless otherwise agreed by JieJie.

Information furnished in this document is believed to be accurate and reliable. However, Jiangsu JieJie Microelectronics Co., Ltd. assumes no responsibility for the consequences of use without consideration for such information nor use beyond it.

Information mentioned in this document is subject to change without notice, apart from that when an agreement is signed, Jiangsu JieJie complies with the agreement.

Products and information provided in this document have no infringement of patents. Jiangsu JieJie assumes no responsibility for any infringement of other rights of third parties which may result from the use of such products and information.

This document is the 1.2nd version which is made in 20-Apr-2026. This document supersedes and replaces all information previously supplied.

 is a registered trademark of Jiangsu JieJie Microelectronics Co., Ltd.

Copyright ©2026 Jiangsu JieJie Microelectronics Co., Ltd. Printed All rights reserved.